

OWNER'S CERTIFICATE:

THIS IS TO CERTIFY THAT THE UNDERSIGNED, TOLL NV LIMITED PARTNERSHIP, A NEVADA LIMITED PARTNERSHIP, IS THE OWNER OF THE TRACT OF LAND REPRESENTED ON THIS PLAT AND HAS CONSENTED TO THE PREPARATION AND RECORDATION OF THIS PLAT AND THAT THE SAME IS EXECUTED IN COMPLIANCE WITH AND SUBJECT TO THE PROVISIONS OF N.R.S. CHAPTERS 116, 278, 278A AND TITLE 17 OF THE CITY OF SPARKS; AND DOES HEREBY DEDICATE TO THE CITY OF SPARKS ALL PUBLIC STREETS, ALLEYS, RIGHTS-OF-WAY AND PUBLIC PLACES, AS DESIGNATED HEREON, TOGETHER WITH ALL APPURTENANCES THERETO, FOR PUBLIC USE FOREVER; AND HEREBY GRANTS TO THE CITY OF SPARKS, TRUCKEE MEADOWS WATER AUTHORITY, ALL PUBLIC UTILITY CABLE TV COMPANIES, THEIR SUCCESSORS AND ASSIGNS, THOSE PERMANENT EASEMENTS DELINEATED HEREON FOR THE CONSTRUCTION AND MAINTENANCE OF SANITARY SEWER, STORM DRAIN, SURFACE DRAINAGE, UTILITY AND CABLE TV SYSTEMS AND APPURTENANCES, TOGETHER WITH THE RIGHT OF INGRESS THERETO AND EGRESS THEREFROM FOREVER. THE OWNER AND ITS ASSIGNS AGREE TO THE USE OF RESIDENTIAL WATER METERS.

TOLL NV LIMITED PARTNERSHIP,
A NEVADA LIMITED PARTNERSHIP

GARY M. MAYO, Gary M. Mayo
PRESIDENT

11-20-19
DATE

ACKNOWLEDGMENT:

STATE OF NEVADA }
COUNTY OF Washoe } SS

THIS INSTRUMENT WAS ACKNOWLEDGED BEFORE ME ON THE 20th DAY OF November, 2019, BY GARY M. MAYO AS PRESIDENT OF TOLL NV LIMITED PARTNERSHIP, A NEVADA LIMITED PARTNERSHIP.

[Signature]
NOTARY PUBLIC

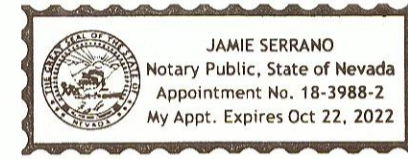

SECURITY INTEREST HOLDER'S CERTIFICATE:

THIS IS TO CERTIFY THAT THE FOLLOWING HAVE CONSENTED TO THE PREPARATION AND RECORDATION OF THIS PLAT BY SEPARATE DOCUMENT AND THE DEDICATION OF ALL UTILITY EASEMENTS SHOWN HEREON, AND HEREBY RELINQUISHES AND SUBORDINATES ANY LIENS HELD BY THE UNDERSIGNED IN FAVOR OF SUCH UTILITY EASEMENTS.

RRW STONEBROOK, LLC, A DELAWARE LIMITED LIABILITY COMPANY BY DOCUMENT NO. 4972454
OFFICIAL RECORDS OF WASHOE COUNTY, NEVADA (REFERENCE PERFORMANCE DEED OF TRUST DOCUMENT NO. 4934792)

TITLE COMPANY CERTIFICATE:

THE UNDERSIGNED HEREBY CERTIFIES THAT THIS PLAT HAS BEEN EXAMINED AND THAT TOLL NV LIMITED PARTNERSHIP, A NEVADA LIMITED PARTNERSHIP, OWN OF RECORD AN INTEREST IN THE LANDS DELINEATED HEREON AND THAT THEY ARE THE ONLY OWNERS OF RECORD OF SAID LAND; THAT ALL THE OWNERS OF RECORD OF THE LAND HAVE SIGNED THE FINAL MAP; THAT WESTERN ALLIANCE BANK, AN ARIZONA CORPORATION HOLDS OF RECORD A SECURITY INTEREST IN THE LAND TO BE DIVIDED AND THAT THEY ARE THE ONLY HOLDER'S OF RECORD OF A SECURITY INTEREST IN SAID LAND; AND THAT THERE ARE NO LIENS OF RECORD AGAINST THE COMMON-INTEREST COMMUNITY, OR ANY PART THEREOF, FOR DELINQUENT STATE, COUNTY, MUNICIPAL, FEDERAL OR LOCAL TAXES OR ASSESSMENTS COLLECTED AS TAXES OR SPECIAL ASSESSMENTS, AND THAT A GUARANTEE DATED 11-29-19 FOR THE BENEFIT OF THE CITY OF SPARKS, WASHOE COUNTY, NEVADA, HAS BEEN ISSUED WITH REGARD TO ALL OF THE ABOVE.

WESTMINSTER TITLE AGENCY, INC.
BY: Steve A. Koester 11/25/2019
NAME/TITLE (PRINT) DATE
Steve A. Koester / Title Officer

UTILITY COMPANIES' CERTIFICATE:

THE UTILITY EASEMENTS SHOWN ON THIS PLAT HAVE BEEN CHECKED, ACCEPTED AND APPROVED BY THE UNDERSIGNED CABLE TV AND UTILITY COMPANIES AND TRUCKEE MEADOWS WATER AUTHORITY.

Katharine Perkins 12/2/19
SIERRA PACIFIC POWER COMPANY D/B/A NV ENERGY DATE
NAME/TITLE (PRINT) KATHERINE PERKINS ASSEC ROW AGENT

Cliff Coogan 11-13-19
NEVADA-BELL D/B/A AT&T NEVADA DATE
NAME/TITLE (PRINT) CLIFF COOGAN MGR OSP PLANNING

Bob Givens 11-12-19
CHARTER COMMUNICATIONS DATE
NAME/TITLE (PRINT) BOB GIVENS Construction Supervisor

John R. Zimmerman 11/21/19
TRUCKEE MEADOWS WATER AUTHORITY DATE
NAME/TITLE (PRINT) John R. Zimmerman, Water Resources Manager

STONEBROOK VILLAGE D2
NEW URBAN DISTRICT

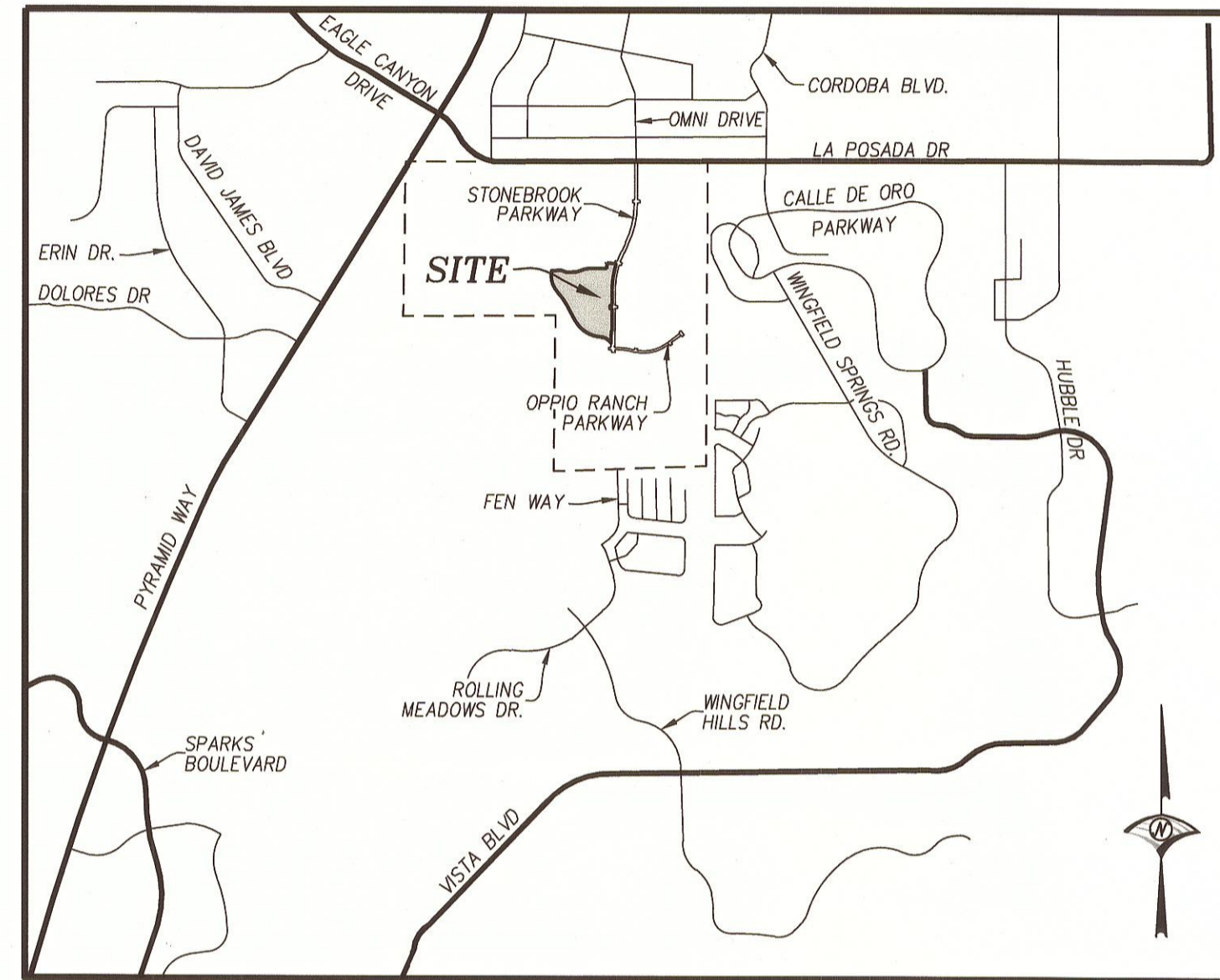

VICINITY MAP
N.T.S.

CITY COUNCIL'S CERTIFICATE:

A TENTATIVE MAP OF THIS SUBDIVISION WAS APPROVED BY THE CITY COUNCIL OF THE CITY OF SPARKS, WASHOE COUNTY, NEVADA ON THE 16TH DAY OF JANUARY, 2014, AND IN ACCORDANCE WITH N.R.S. 278.360, A ONE YEAR EXTENSION WAS PROVIDED DUE TO CITY COUNCIL APPROVAL OF STONEBROOK VILLAGES C1 ON THE 11TH DAY OF OCTOBER, 2018 AND RECORDED AS TRACT MAP NO. 5288, FILE NO. 4859701. THIS FINAL MAP WAS APPROVED BY THE CITY COUNCIL OF THE CITY OF SPARKS, WASHOE COUNTY, NEVADA ON THIS 20 DAY OF 20 AND THE CITY COUNCIL APPROVES AND ACCEPTS ALL PUBLIC STREETS, ALLEYS, RIGHTS-OF-WAY, PUBLIC PLACES AND EASEMENTS, TOGETHER WITH ALL APPURTENANCES THERETO, FOR THE BENEFIT OF THE PUBLIC IN CONFORMITY WITH THE TERMS OF THE OFFER OF DEDICATION SHOWN HEREON.

Ronald E. Smith _____ DATE _____
MAYOR
ATTEST: _____ DATE _____
CITY CLERK AND CLERK OF THE CITY COUNCIL

PLANNING DEPARTMENT CERTIFICATE

THIS FINAL MAP IS IN SUBSTANTIAL COMPLIANCE WITH THE TENTATIVE MAP OF STONEBROOK PHASE 1, PCN13014, AS APPROVED BY THE CITY COUNCIL OF THE CITY OF SPARKS ON THE 16TH DAY OF JANUARY, 2014 AND ALL CONDITIONS OF APPROVAL HAVE BEEN MET.

Armando Ornelas 1/23/2020
ASSISTANT COMMUNITY SERVICES DIRECTOR DATE

TAX CERTIFICATE:

THE UNDERSIGNED HEREBY CERTIFIES THAT ALL PROPERTY TAXES ON THE LAND SHOWN HEREON FOR THE FISCAL YEAR HAVE BEEN PAID AND THAT THE FULL AMOUNT OF ANY DEFERRED PROPERTY TAXES FOR THE CONVERSION OF THE PROPERTY FROM AGRICULTURAL USE HAS BEEN PAID PURSUANT TO N.R.S. 361A.265.

APN: 528-311-15
Steven Thibault 11-19-2019
WASHOE COUNTY TREASURER DATE
Deputy Treasurer
NAME / TITLE (PRINT)

DISTRICT BOARD OF HEALTH CERTIFICATE:

THIS FINAL MAP IS APPROVED BY THE WASHOE COUNTY DISTRICT BOARD OF HEALTH. THIS APPROVAL CONCERNS SEWAGE DISPOSAL, WATER POLLUTION, WATER QUALITY AND WATER SUPPLY FACILITIES. THIS MAP HAS BEEN FOUND TO MEET ALL APPLICABLE REQUIREMENTS AND PROVISIONS OF THE ENVIRONMENTAL HEALTH SERVICES DIVISION OF THE WASHOE COUNTY HEALTH DISTRICT.

James J. English 01/23/2020
FOR THE DISTRICT BOARD OF HEALTH DATE
NAME / TITLE (PRINT) EHS Supervisor

DIVISION OF WATER RESOURCES CERTIFICATE

THIS FINAL MAP IS APPROVED BY THE STATE OF NEVADA DIVISION OF WATER RESOURCES OF THE DEPARTMENT OF CONSERVATION AND NATURAL RESOURCES CONCERNING WATER QUANTITY, SUBJECT TO THE REVIEW OF APPROVAL ON FILE IN THIS OFFICE.

Malcolm J. Wilson, P.E. 11/21/19
DIVISION OF WATER RESOURCES DATE
NAME/TITLE PRINTED Chief Water Rights Section

COUNTY SURVEYOR'S CERTIFICATE:

I HEREBY CERTIFY THAT I HAVE EXAMINED THIS PLAT AND PERFORMED A TECHNICAL MAP CHECK OF THE GEOMETRIC DATA SHOWN HEREON, PURSUANT TO THAT INTERLOCAL AGREEMENT RECORDED IN THE OFFICIAL RECORDS OF WASHOE COUNTY, NEVADA, AS DOCUMENT NO. 2233806, AND I AM SATISFIED SAID GEOMETRIC DATA IS TECHNICALLY CORRECT.

WAYNE HANDROCK, P.L.S. 20464
WASHOE COUNTY SURVEYOR

GOVERNING AGENCY CERTIFICATE

I HEREBY CERTIFY THAT I AM THE CITY ENGINEER FOR THE CITY OF SPARKS, WASHOE COUNTY, NEVADA, AND THAT I HAVE EXAMINED THIS PLAT AND ALL APPLICABLE PROVISIONS OF THE LAWS OF THE STATE OF NEVADA AND ORDINANCES OF THE CITY OF SPARKS HAVE BEEN COMPLIED WITH, THAT I AM SATISFIED SAID PLAT IS TECHNICALLY CORRECT, EXCEPTING THE GEOMETRIC DATA SHOWN HEREON, AS REVIEWED BY THE WASHOE COUNTY SURVEYOR PURSUANT TO THE INTERLOCAL AGREEMENT RECORDED IN THE OFFICIAL RECORDS OF WASHOE COUNTY, NEVADA AS DOCUMENT NO. 2233806.

Jon R. Ericson 1/23/2020
JON R. ERICSON, P.E. P.T.O.E., CITY ENGINEER DATE

SURVEYOR'S CERTIFICATE:

I, DANIEL A. BIGRIGG, A PROFESSIONAL LAND SURVEYOR LICENSED IN THE STATE OF NEVADA, CERTIFY THAT:

- THIS PLAT REPRESENTS THE RESULTS OF A SURVEY CONDUCTED UNDER MY DIRECT SUPERVISION AT THE INSTANCE OF TOLL NV LIMITED PARTNERSHIP, A NEVADA LIMITED PARTNERSHIP.
- THE LANDS SURVEYED LIE WITHIN A PORTION OF THE NORTH ONE-HALF AND THE SOUTHEAST ONE-QUARTER OF SECTION 2, TOWNSHIP 20 NORTH, RANGE 20 EAST, M.D.M., CITY OF SPARKS, WASHOE COUNTY, NEVADA, AND THE SURVEY WAS COMPLETED ON 11/12/2019.
- THIS PLAT COMPLIES WITH THE APPLICABLE STATE STATUTES AND ANY LOCAL ORDINANCES IN EFFECT ON THE DATE THAT THE GOVERNING BODY GAVE ITS FINAL APPROVAL, AND THE SURVEY WAS CONDUCTED IN ACCORDANCE WITH CHAPTER 625 OF THE NEVADA ADMINISTRATIVE CODE.
- THE MONUMENTS DEPICTED ON THE PLAT WILL BE OF THE CHARACTER SHOWN AND OCCUPY THE POSITIONS INDICATED BY October 25, 2019, AND AN APPROPRIATE FINANCIAL GUARANTEE WILL BE POSTED WITH THE GOVERNING BODY BEFORE RECORDATION TO ENSURE THE INSTALLATION OF THE MONUMENTS.

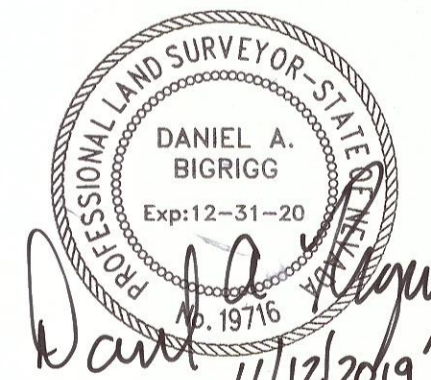

DANIEL A. BIGRIGG P.L.S.
NEVADA CERTIFICATE NO. 19716

FILE NO. _____
FILED FOR RECORD AT THE REQUEST OF _____
ON THIS _____ DAY OF _____
2020, AT _____ MINUTES PAST _____
O'CLOCK, _____, OFFICIAL RECORDS OF WASHOE COUNTY NEVADA.

COUNTY RECORDER
BY: _____ DEPUTY
FEE: _____

OFFICIAL PLAT OF
STONEBROOK VILLAGE D2
BEING A DIVISION OF PARCEL A PER T.M. 5236 SITUATE WITHIN THE NORTH 1/2 & SE 1/4 OF SECTION 2, T.20N., R.20E., M.D.M.

SPARKS WASHOE COUNTY NEVADA
JOB NO. 1407.030

WOOD RODGERS
BUILDING RELATIONSHIPS ONE PROJECT AT A TIME
1981 Corporate Blvd Reno, NV 89502 Tel 775.823.4088 Fax 775.823.4088

SHEET 1 OF 3

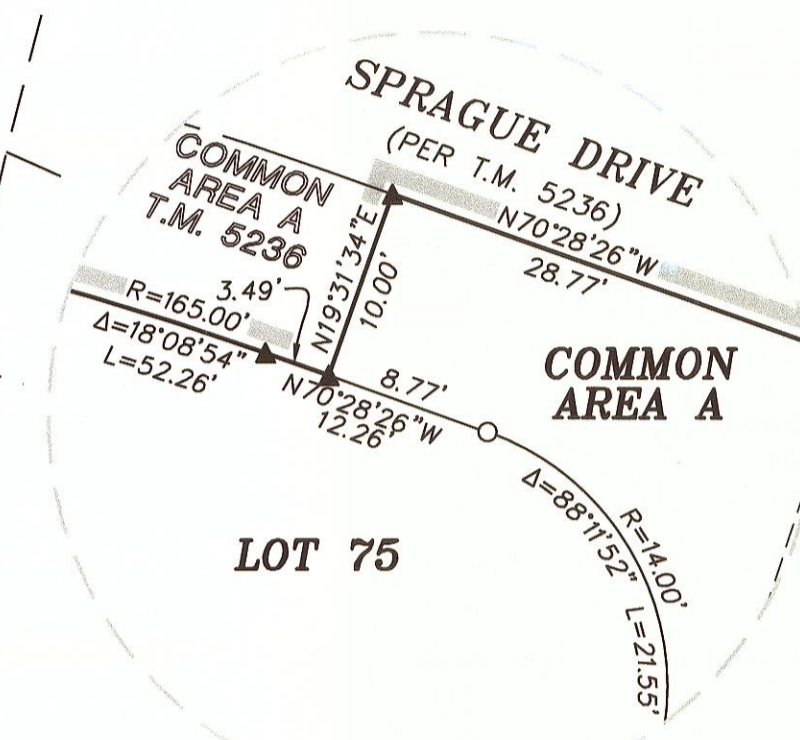
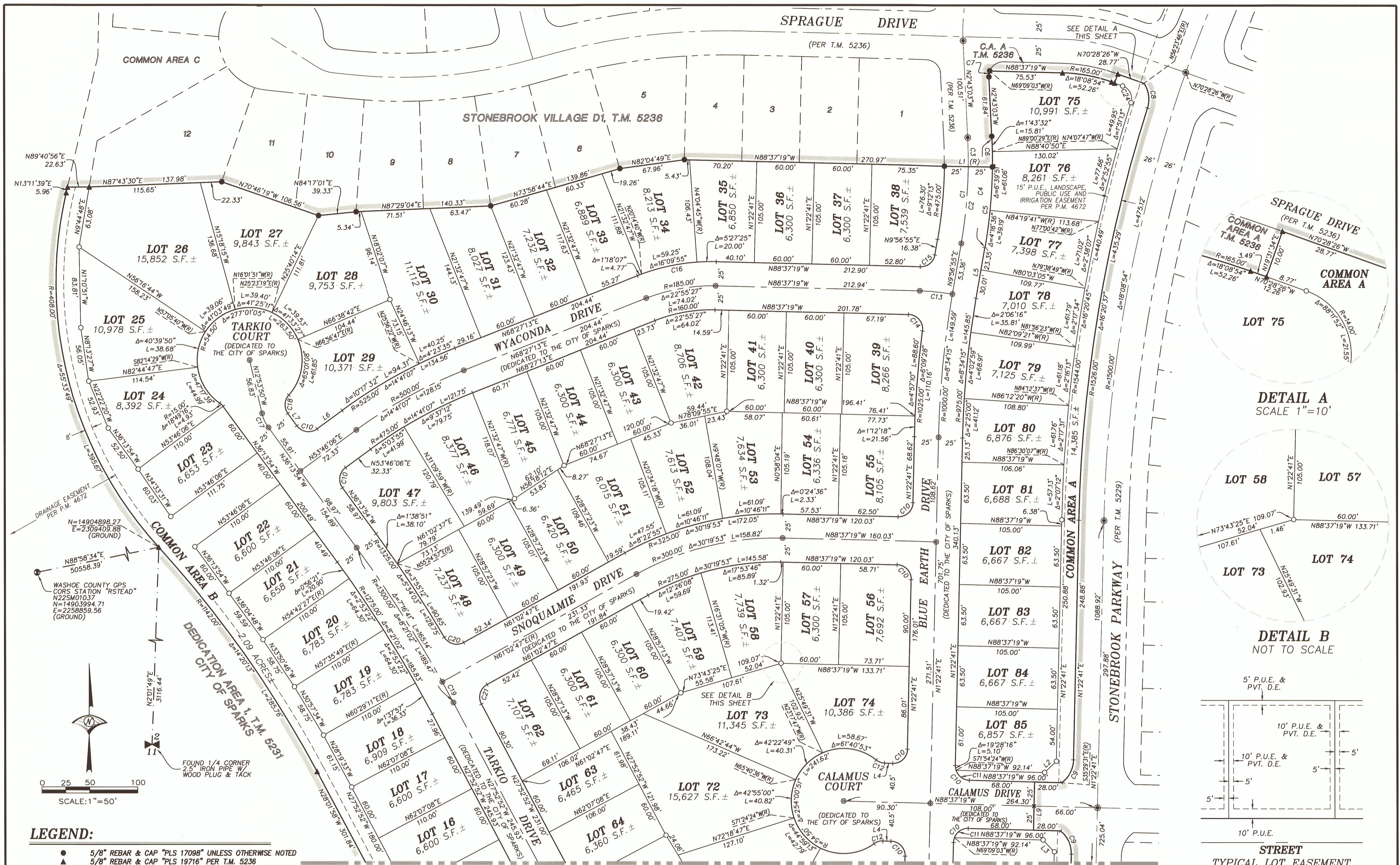

DETAIL A
SCALE 1"=10'

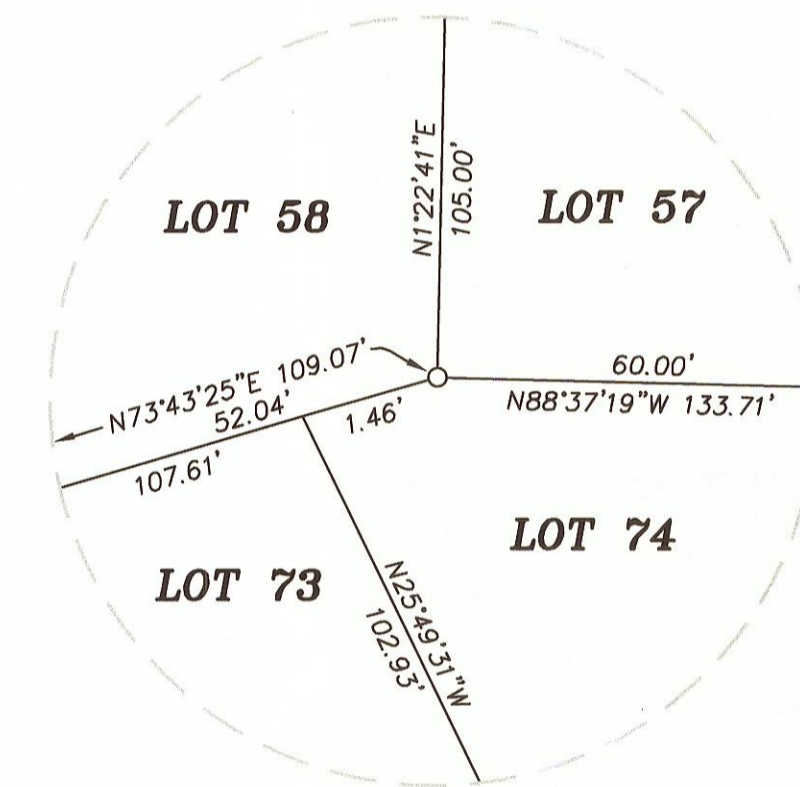

DETAIL B
NOT TO SCALE

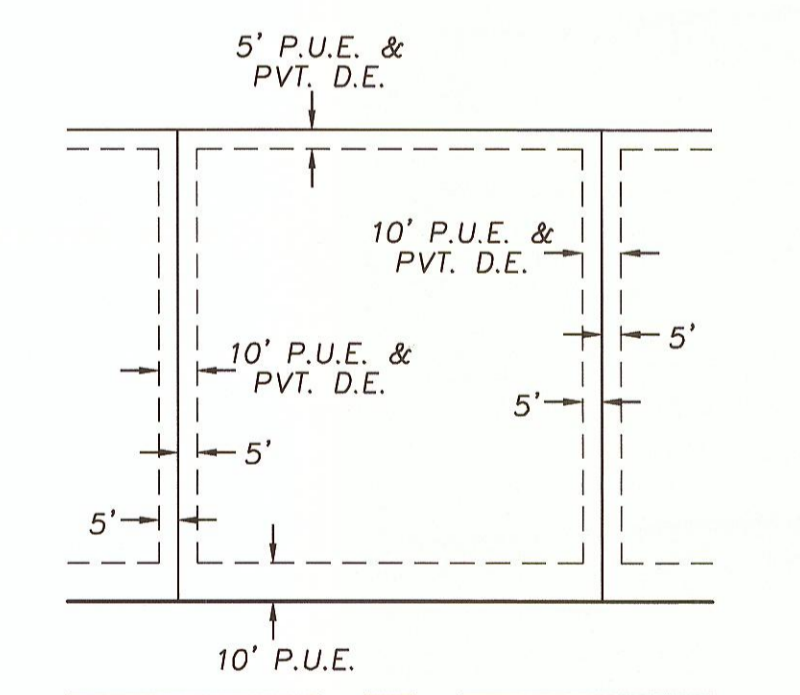

STREET
TYPICAL LOT EASEMENT
DETAIL
NOT TO SCALE

- LEGEND:**
- 5/8" REBAR & CAP "PLS 17098" UNLESS OTHERWISE NOTED
 - 5/8" REBAR & CAP "PLS 19716" PER T.M. 5236
 - STANDARD STREET CENTERLINE MONUMENT PER T.M. 5229 & 5236
 - ⊙ TYPICAL SECTION CORNER - AS NOTED
 - WASHOE COUNTY G.P.S. MONUMENT - AS NOTED
 - SET 5/8" REBAR & CAP - PLS 19716 OR SCRIBED CURB ON PROPERTY LINE EXTENSION
 - STANDARD CENTERLINE STREET MONUMENT TO BE SET
 - DIMENSION POINT, NOTHING FOUND OR SET
 - RADIAL BEARING
 - S.F. SQUARE FEET
 - T.M. SUBDIVISION TRACT MAP
 - P.M. PARCEL MAP
 - R.O.S. RECORD OF SURVEY
 - C.A. COMMON AREA
 - SUBDIVISION BOUNDARY
 - GRAPHIC BORDER
 - LOT LINE
 - RIGHT-OF-WAY
 - ROAD CENTERLINES
 - ADJACENT PARCEL
 - ADJACENT RIGHT-OF-WAY
 - EASEMENT AS NOTED
 - TIE

CURVE TABLE

NO.	RADIUS	DELTA	LENGTH
C1	500.00	123.95	110.53
C2	500.00	91.21	80.32
C3	500.00	327.46	30.22
C4	525.00	123.95	116.06
C5	525.00	91.21	84.33
C6	525.00	327.46	31.73
C7	15.00	233.40	6.17
C8	30.00	51.93	26.87
C9	30.00	53.07	27.82
C10	15.00	90.00	23.56
C11	15.00	70.31	18.46
C12	15.00	37.00	9.69
C13	230.00	8.30	34.12
C14	15.00	96.09	26.17
C15	15.00	81.25	21.32
C16	210.00	22.55	84.02
C17	40.00	23.20	16.29
C18	15.00	78.11	20.47
C19	1300.00	1.04	24.33
C20	15.00	88.17	23.11
C21	15.00	88.55	23.28
C24	14.00	88.11	21.55

LINE TABLE

NO.	BEARING	LENGTH
L1	N89°51'7"W	50.00
L2	N46°22'41"E	16.92
L3	N43°37'19"W	16.92
L4	N88°37'19"W	8.47
L5	N9°56'55"E	53.36
L6	N53°46'06"E	32.33
L7	N36°13'54"W	15.91
L8	N1°22'41"E	50.00
L9	N1°22'41"E	50.00

PROFESSIONAL LAND SURVEYOR STATE OF NEVADA
DANIEL A. BIGRIGG
Exp: 12-31-20
1976

RIGHT-OF-WAY = 4.47 ACRES±
COMMON AREAS = 2.42 ACRES±
LOT AREA (85 LOTS) = 15.04 ACRES±
TOTAL AREA = 21.93 ACRES±

OFFICIAL PLAT
OF
STONEBROOK VILLAGE D2
BEING A DIVISION OF PARCEL A PER T.M. 5236
SITUATE WITHIN THE NORTH 1/2 & SE 1/4 OF
SECTION 2, T.20N., R.20E., M.D.M.
SPARKS WASHOE COUNTY NEVADA
JOB NO. 1407.030

WOOD RODGERS
BUILDING RELATIONSHIPS ONE PROJECT AT A TIME
1961 Corporate Blvd Reno, NV 89602 Tel 775.823.4068 Fax 775.823.4068

SHEET 2
OF 3

MATCHLINE SEE SHEET 2 OF 3

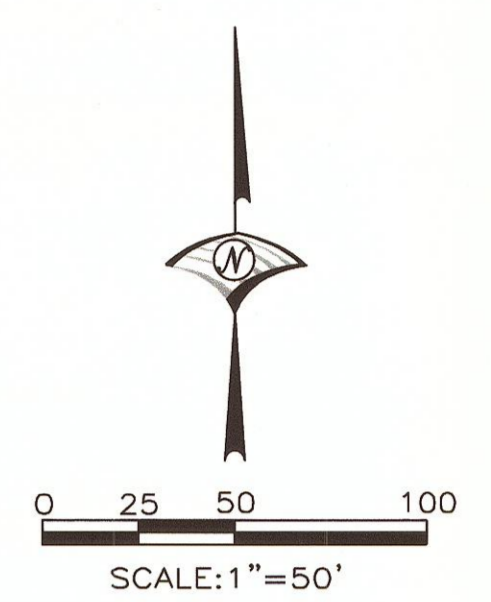
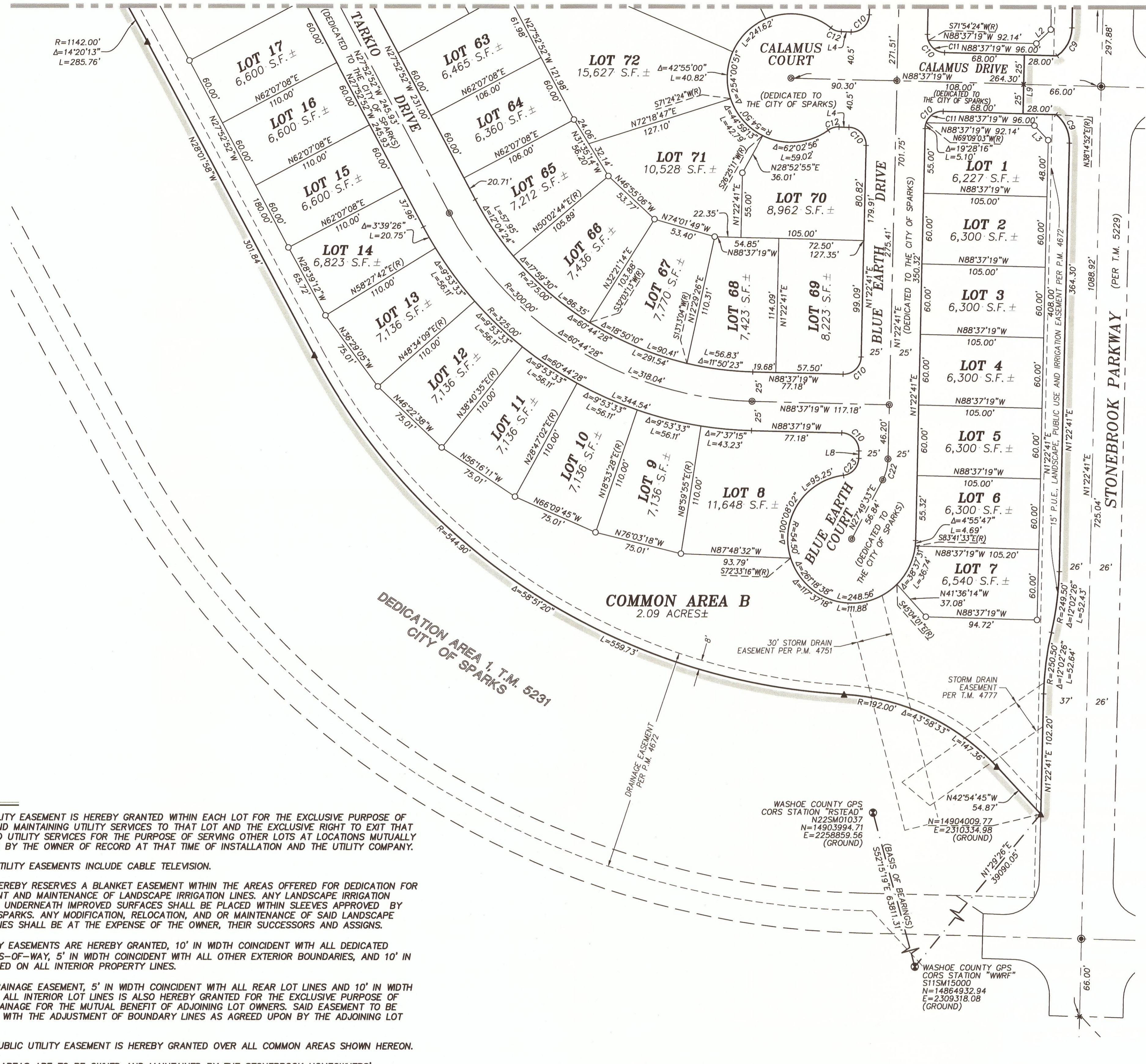

BASIS OF BEARINGS:

NEVADA STATE PLANE COORDINATE SYSTEM, WEST ZONE, NORTH AMERICAN DATUM OF 1983/1994, HIGH ACCURACY REFERENCE NETWORK (NAD 83/94-HARN), AS DETERMINED USING REAL TIME KINEMATIC (RTK) GPS OBSERVATIONS WITH CORRECTIONS TRANSMITTED BY THE NORTHERN NEVADA COOPERATIVE REAL TIME NETWORK GPS (NNCRN GPS). THE BEARING BETWEEN GPS REFERENCE STATION "RSTEAD" - N22SM01037 AND "WWRP" - S11SM15000 IS TAKEN AS SOUTH 52°15'19" EAST. ALL DIMENSIONS SHOWN ARE GROUND DISTANCES. COMBINED GRID-TO-GROUND FACTOR = 1.000197939.

LEGEND:

- 5/8" REBAR & CAP "PLS 17098" UNLESS OTHERWISE NOTED
- 5/8" REBAR & CAP "PLS 19716" PER T.M. 5236
- STANDARD STREET CENTERLINE MONUMENT PER T.M. 5229 & 5236
- ⊙ TYPICAL SECTION CORNER - AS NOTED
- ⊙ WASHOE COUNTY G.P.S. MONUMENT - AS NOTED
- ⊙ SET 5/8" REBAR & CAP - PLS 19716 OR SCRIBED CURB ON PROPERTY LINE EXTENSION
- ⊙ STANDARD CENTERLINE STREET MONUMENT TO BE SET
- ⊙ DIMENSION POINT, NOTHING FOUND OR SET
- (R) RADIAL BEARING
- S.F. SQUARE FEET
- T.M. SUBDIVISION TRACT MAP
- P.M. PARCEL MAP
- R.O.S. RECORD OF SURVEY
- C.A. COMMON AREA
- SUBDIVISION BOUNDARY
- GRAPHIC BORDER
- LOT LINE
- RIGHT-OF-WAY
- ROAD CENTERLINES
- ADJACENT PARCEL
- ADJACENT RIGHT-OF-WAY
- EASEMENT AS NOTED
- TIE

REFERENCES:

1. RECORD OF SURVEY NO. 910, FILE NO. 381618, 10/14/1975.
 2. LAND MAP NO. 143, FILE NO. 1673249, 5/13/1993.
 3. RECORD OF SURVEY NO. 3193, FILE NO. 2075580, 2/26/1997.
 4. RECORD OF SURVEY NO. 3626, FILE NO. 2353622, 6/22/1999.
 5. RECORD OF SURVEY NO. 3627, FILE NO. 2353625, 6/22/1999.
 6. PARCEL MAP NO. 3825, FILE NO. 2619335, 11/21/2001.
 7. RECORD OF SURVEY NO. 4762, FILE NO. 3407484, 6/29/2006.
 8. PARCEL MAP NO. 4672, FILE NO. 3453009, 10/19/2006.
 9. PARCEL MAP NO. 4673, FILE NO. 3453010, 10/19/2006.
 10. RECORD OF SURVEY NO. 4891, FILE NO. 3523784, 4/23/2007.
 11. PARCEL MAP NO. 4751, FILE NO. 3523785, 4/23/2007.
 12. TRACT MAP NO. 4777, FILE NO. 3531508, 5/11/2007.
 13. PARCEL MAP NO. 4777, FILE NO. 3535657, 5/23/2007.
 14. TRACT MAP NO. 4844, FILE NO. 3604696, 12/20/2007.
 15. ORDER VACATING STREET DEDICATION DOC. NO. 4059100, 11/16/2011.
 16. DEDICATION TRACT MAP NO. 5229, FILE NO. 4754345, 10/17/2017.
 17. DEDICATION TRACT MAP NO. 5230, FILE NO. 4754354, 10/17/2017.
 18. DEDICATION TRACT MAP NO. 5231, FILE NO. 4754362, 10/17/2017.
 19. SUBDIVISION TRACT MAP NO. 5236, FILE NO. 4759544, 11/1/2017.
- ALL THE ABOVE ARE OFFICIAL RECORDS OF WASHOE COUNTY, NEVADA

NOTES:

1. A PUBLIC UTILITY EASEMENT IS HEREBY GRANTED WITHIN EACH LOT FOR THE EXCLUSIVE PURPOSE OF INSTALLING AND MAINTAINING UTILITY SERVICES TO THAT LOT AND THE EXCLUSIVE RIGHT TO EXIT THAT LOT WITH SAID UTILITY SERVICES FOR THE PURPOSE OF SERVING OTHER LOTS AT LOCATIONS MUTUALLY AGREED UPON BY THE OWNER OF RECORD AT THAT TIME OF INSTALLATION AND THE UTILITY COMPANY.
2. ALL PUBLIC UTILITY EASEMENTS INCLUDE CABLE TELEVISION.
3. THE OWNER HEREBY RESERVES A BLANKET EASEMENT WITHIN THE AREAS OFFERED FOR DEDICATION FOR THE PLACEMENT AND MAINTENANCE OF LANDSCAPE IRRIGATION LINES. ANY LANDSCAPE IRRIGATION LINES PLACED UNDERNEATH IMPROVED SURFACES SHALL BE PLACED WITHIN SLEEVES APPROVED BY THE CITY OF SPARKS. ANY MODIFICATION, RELOCATION, AND OR MAINTENANCE OF SAID LANDSCAPE IRRIGATION LINES SHALL BE AT THE EXPENSE OF THE OWNER, THEIR SUCCESSORS AND ASSIGNS.
4. PUBLIC UTILITY EASEMENTS ARE HEREBY GRANTED, 10' IN WIDTH COINCIDENT WITH ALL DEDICATED STREET RIGHTS-OF-WAY, 5' IN WIDTH COINCIDENT WITH ALL OTHER EXTERIOR BOUNDARIES, AND 10' IN WIDTH CENTERED ON ALL INTERIOR PROPERTY LINES.
5. A PRIVATE DRAINAGE EASEMENT, 5' IN WIDTH COINCIDENT WITH ALL REAR LOT LINES AND 10' IN WIDTH CENTERED ON ALL INTERIOR LOT LINES IS ALSO HEREBY GRANTED FOR THE EXCLUSIVE PURPOSE OF PROVIDING DRAINAGE FOR THE MUTUAL BENEFIT OF ADJOINING LOT OWNERS. SAID EASEMENT TO BE RELOCATABLE WITH THE ADJUSTMENT OF BOUNDARY LINES AS AGREED UPON BY THE ADJOINING LOT OWNERS.
6. A BLANKET PUBLIC UTILITY EASEMENT IS HEREBY GRANTED OVER ALL COMMON AREAS SHOWN HEREON.
7. ALL COMMON AREAS ARE TO BE OWNED AND MAINTAINED BY THE STONEBROOK HOMEOWNERS' ASSOCIATION.
8. A BLANKET STORM DRAIN AND SURFACE DRAINAGE EASEMENT IS HEREBY GRANTED TO THE CITY OF SPARKS ACROSS ALL COMMON AREAS SHOWN HEREON.
9. WITH THE DEVELOPMENT OF EACH PARCEL AND PRIOR TO THE ISSUANCE OF ANY BUILDING PERMIT FOR SAID PARCEL, THE OWNER SHALL DEDICATE WATER RIGHTS TO THE SERVICING UTILITY SUFFICIENT TO SERVE THE DEVELOPMENT AND SHALL PROVIDE THE CITY OF SPARKS WITH A WILL SERVE LETTER.
10. EACH LOT CREATED BY THIS MAP IS REQUIRED TO HAVE A SEPARATE WATER METER AND SERVICE LINE. THE WATER PURVEYOR SHALL HAVE THE RIGHT TO INSTALL A WATER METER IN THE 10' PUBLIC UTILITY EASEMENT ADJACENT TO THE STREET TO SERVE EACH PARCEL RESPECTIVELY.

LINE TABLE		
NO.	BEARING	LENGTH
L1	N89°15'17"W	50.00'
L2	N46°22'41"E	16.97'
L3	N43°37'19"W	16.97'
L4	N88°37'19"W	8.47'
L8	N1°22'41"E	6.20'
L9	N1°22'41"E	50.00'

CURVE TABLE			
NO.	RADIUS	DELTA	LENGTH
C9	30.00'	53°07'48"	22.82'
C10	15.00'	90°00'00"	23.56'
C11	15.00'	70°31'44"	18.46'
C12	15.00'	37°00'25"	9.69'
C22	40.00'	26°26'53"	18.46'
C23	15.00'	81°18'38"	21.29'

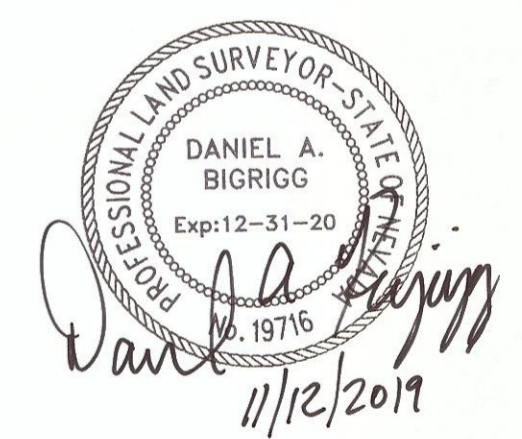

OFFICIAL PLAT
OF
STONEBROOK VILLAGE D2
BEING A DIVISION OF PARCEL A PER T.M. 5236
SITUATE WITHIN THE NORTH 1/2 & SE 1/4 OF
SECTION 2, T.20N., R.20E., M.D.M.

SPARKS WASHOE COUNTY NEVADA
JOB NO. 1407.030

WOOD RODGERS
BUILDING RELATIONSHIPS ONE PROJECT AT A TIME
1961 Corporate Blvd Reno, NV 89502 Tel 775.823.4088 Fax 775.823.4088

SHEET 3
OF 3